

CITY OF LONG BEACH
 PLANNING AND BUILDING DEPARTMENT
TYPICAL DWELLING DETAILS

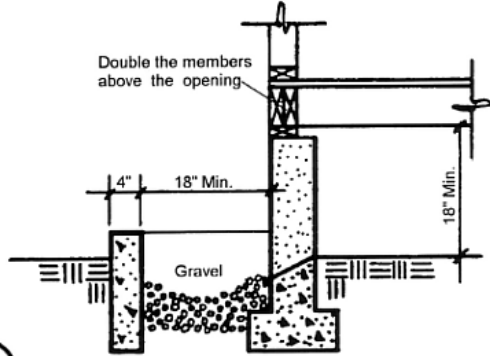

TYPICAL CRAWL DETAIL

Rafters shall be nailed to adjacent ceiling joists to form a continuous tie between exterior walls when such joists are parallel to the rafters. Where not parallel, rafters shall be tied to 1-inch by 4-inch minimum size crossies. Rafter ties shall be spaced not more than 4 feet on center.

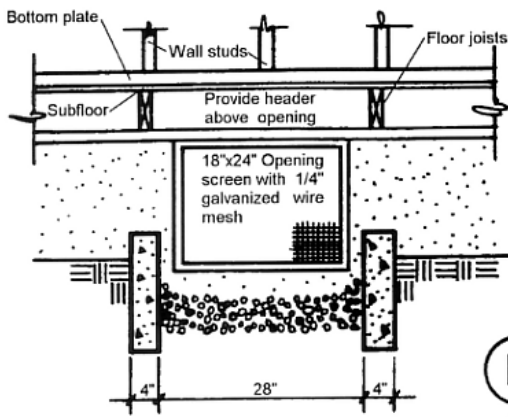
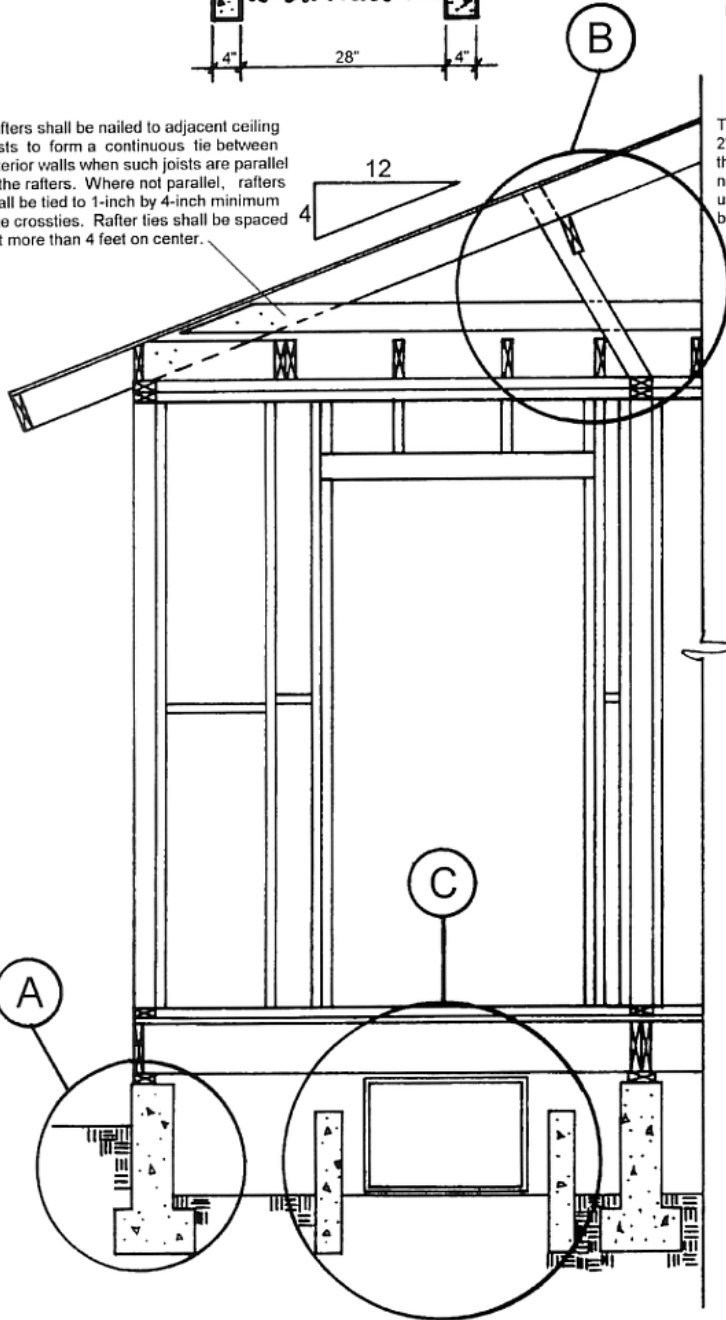

The maximum span of a 2"x4" purlin is 4 feet and 6 feet for a 2"x6" purlin, but in no case shall the purlin be smaller than the supported rafter. Struts supporting purlins shall not be smaller than 2"x4" members. The unbraced length of a strut shall not be greater than 8 feet.

TYPICAL PURLIN DETAIL

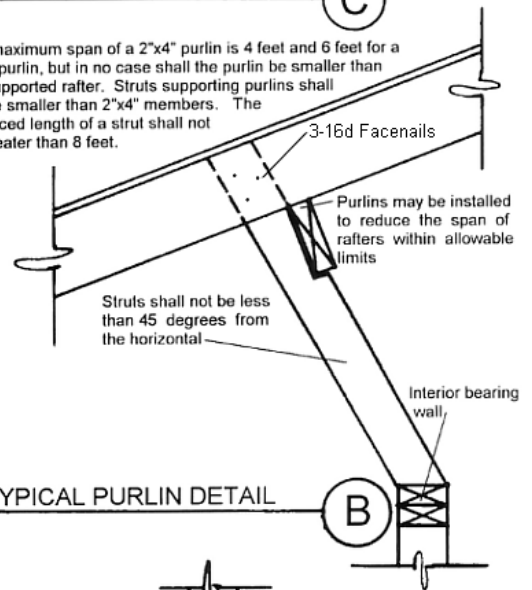

EXTERIOR BEARING FOOTING

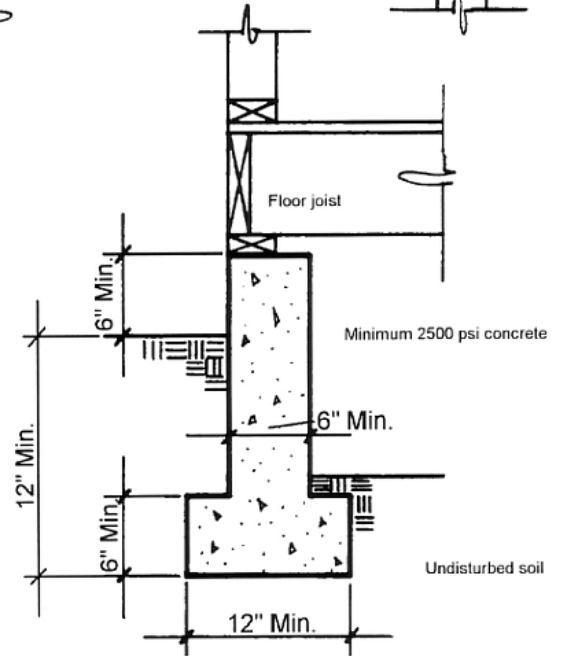

CITY OF LONG BEACH
 PLANNING AND BUILDING DEPARTMENT
TYPICAL DWELLING DETAILS

Ridge board shall be minimum 1 inch nominal thickness and not less in depth than the end cut of rafter.
 Boundary nail roof sheathing to ridge board 8d nails 6" o.c.

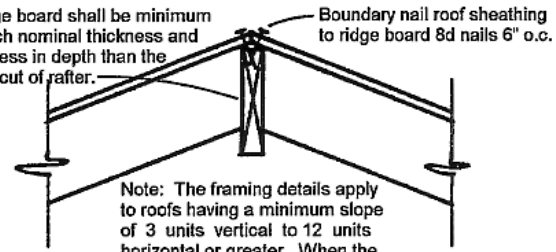

Note: The framing details apply to roofs having a minimum slope of 3 units vertical to 12 units horizontal or greater. When the roof slope is less than 3 - 12 the members supporting rafters and ceiling joists shall be designed as beams.

Typical Ridge Detail (C)

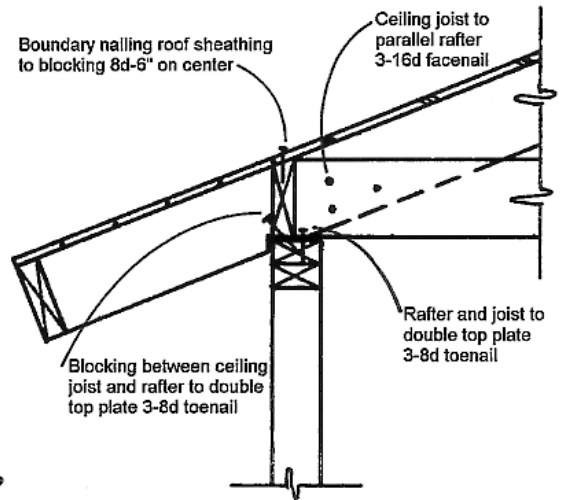
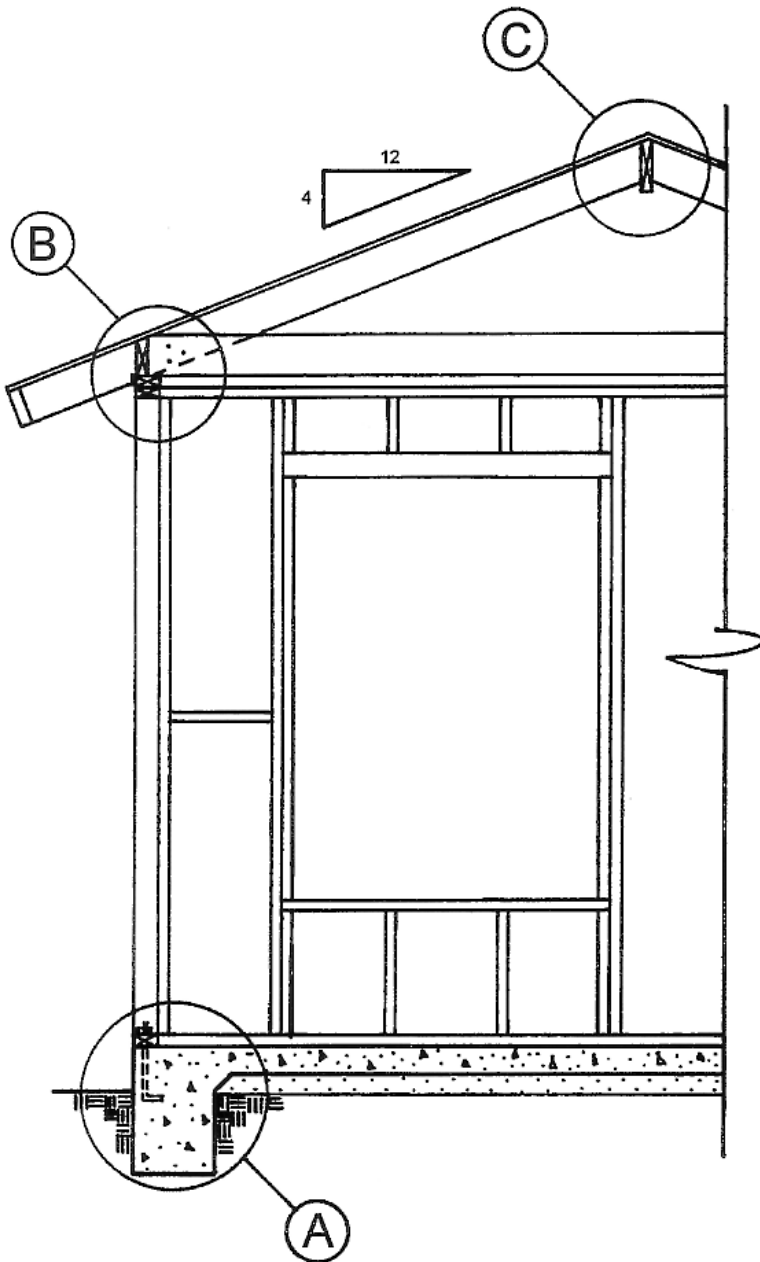

Typical Eave Detail (B)

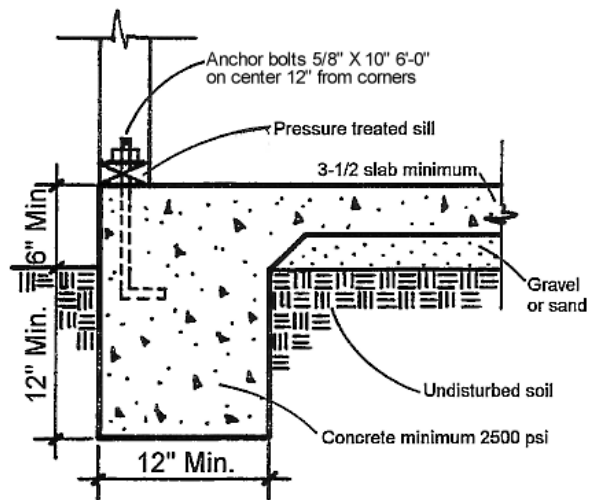

Exterior Bearing Footing (A)